

Technical Data

Typ	Type	Type		P 910	P 1510
Nennleistung (S1-Betr.)	Power rated (S1)	Puissance nominale (S1)	W	750	1000
Nennspannung	Nominal voltage	Tension nominale	V	132	140
Nenn Drehmoment	Rated torque	Couple nominale	Nm	2.5	3.5
Spitzendrehmoment	Peak torque	Couple cretre	Nm	7.5	10.5
Nenn Drehzahl	Rated speed	Vitesse nominale	min ⁻¹	3000	3000
Max. Drehzahl	Max. speed	Vitesse maxi	min ⁻¹	4000	4000
Nennstrom	Rated current	Courant nominale	A	7.1	10.0
Spitzenstrom	Peak current	Courant maxi	A	21.3	30.0
Spannungskonstante	Voltage constant	Constante de tension	V/1000min ⁻¹	40	40
Drehmomentkonstante	Torque constant	Constante de couple	Nm/A	0.35	0.35
Elektr. Zeitkonstante	Electr. time constant	Const. de temps electr.	ms	3.1	7.3
Mech. Zeitkonstante	Mech. time constant	Const. de temps mec.	ms	30	20
Therm. Zeitkonstante	Therm. time constant	Const. de temps therm.	min	75	75
Ankerträgheitsmoment	Rotor inertia moment	Inertie rotor	Kgm ² x10 ⁻³	1.12	1.90
Ankerinduktivität	Armature inductance	Inducatance rotor	mH	3.8	10.7
Ankerwiderstand	Armature resistance	Resistance rotor	Ohm	1.25	1.1
Anschlußwiderstand	Connection resistance	Resistance aux bornes	Ohm	2.5	1.46
Gewicht ohne Bremse	Weight without brake	Poidds sans frein	Kg	8.0	12.6

Drawing

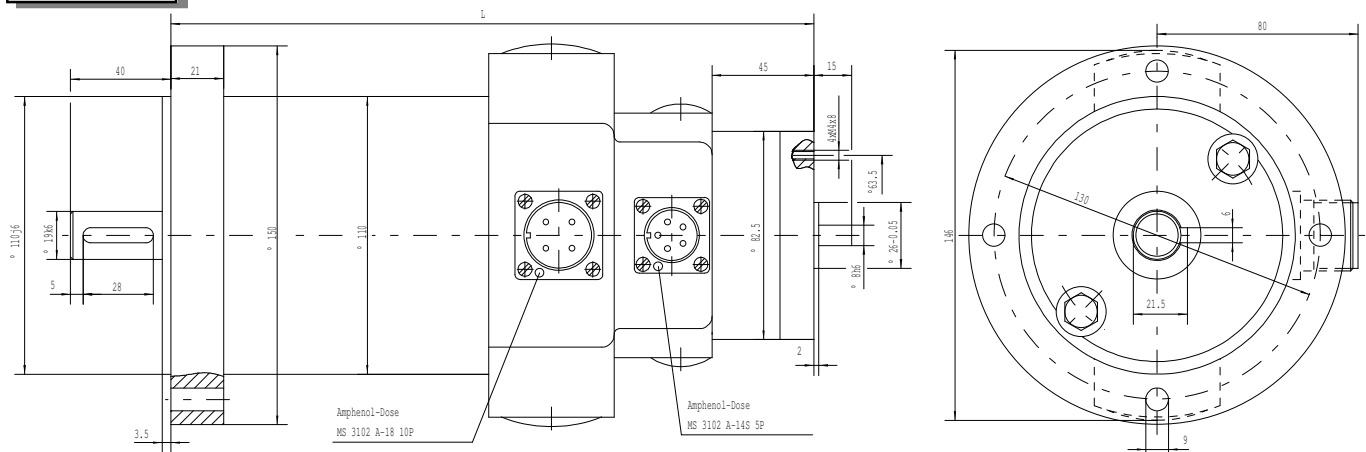

	Lenght without Brake	Lenght with Brake
P 910	296	342
P 1510	340	385

Technical Data of the Tacho-Alternator and the Holding Brake

Typ	Type	Type		P 910	P 1510
Tachogenerator	Tachogenerator	Tachymetrique			
Spannungskonstante	Voltage constant	Constante de tension	V/1000min ⁻¹	14	14
Ankerwiderstand	Armature resistance	Resistance rotor	Ohm	56	56
Rippelfaktor	Ripple factor	Rippel	%	1.5	1.5
Haltebremse	Holding brake	Frein de maintien			
Bremsspannung	Rated voltage	Tension nominale	VDC	24	24
Bremsmoment	Brake torque	Couple de maintien	Nm	1.4	1.4
Schaltleistung	Rated power	Puissance nominale	W	15	15
Gewicht mit Bremse	Weight with brake	Poidds avec frein	Kg	8.4	13.0

Remark

All tacho-alternators are permanent magnet excited continuous current tacho-alternators. The driver of the tacho-alternator is tensional joined to the motor shaft so that the engine speed is provided to the tacho-alternator as unaltered actual value speed.

The carbon brushes used with the tacho-alternator are made of silver graphite.

All tolerances of the technical data are given according to VDE 0530. For all figures not given according to VDE 0530 there is a tolerance of +/- 10%.

With versions built to protection class IP54, a minimal lower torque can be expected due to the installation of shaft packing which causes increased friction.

The technical data given in the table and performance curve refer to a direct-current supply with a valid harmonic content of up to 5%.

The data given applies to application in an ambient temperature from 0°C to 40°C . This temperature range must not be undershot nor exceeded; otherwise an irreversible debilitation of the magnet might be possible.

Technical modifications reserved

Kern GmbH
Antriebstechnik

Gutenbergstraße 11
88046 Friedrichshafen

Tel.: (+49) 07541-5016-0
Fax.: (+49) 07541-5016-28